

POWER QUALITY PERFORMANCE OF MULTI PHOTOVOLTAIC CONNECTED TO GRID UNDER VARIABLE SOLAR TEMPERATURE AND IRRADIANCE LEVEL

¹Adiananda, ²Agus Kiswantonono, ³Amirullah

^{1,2,3}Study Program of Electrical Engineering, University of Bhayangkara Surabaya
Jalan Ahmad Yani 114 Surabaya Indonesia

Email: ¹adi.dirza@gmail.com, ²kiswantonono@gmail.com,
³amirullah@ubhara.ac.id, ³am9520012003@yahoo.com

ABSTRACT

Photovoltaic (PV) other than capable to result power, it also generates harmonics due to the presence of an inverter as a medium to convert DC to AC voltage so can reduce power quality. PV generator also has intermitten characteristic and generate power depend on environment condition e.g. temperature and irradiance level. The paper presents performance improvement of power quality due to the influence of multi PV integration to low voltage distribution line of 380 kV (phase-phase) 50 Hz on point common coupling (PCC) bus under variable solar temperature and irradiance level. The model consists of three PV generator groups with 100 kW active power. In addition to connecting on a three phase grid, PV generator is also connected to three groups of three phase loads with 20 kW active power each. The power quality parameters studied are voltage and current unbalance as well as voltage and current harmonics in eight scenarios PV generator connected on three phase grid. The single tuned filter is used to improve power quality using two conditions before and after filter installed. Multi PV models with three phase generators connected three phase grid, without and with single tuned filters at all irradiance and temperature levels results phase maximum voltage (phase A, B, and C) in relatively stable of 308 and 310 Volt respectively, and generating unbalanced voltage of 0%. The maximum phase current value, for system without single tuned filter at all irradiance and temperature levels are different as 12.5, 9.8, and 10 A, respectively, resulting in unbalanced current of 16.0991%. Under the same condition, single tuned filters are capable to balance maximum phase currents (phase A, B, and C) of 10.45 A respectively, so able to reduce unbalanced current to 0%. The implementation of single tuned filter can reduce unbalanced current values according limit ANSI/IEEE 241-1990. At a constant temperature and irradiance levels are increasing, voltage and current average harmonics (total harmonics distortion) are also increasing. The use of single tuned filter is the most effective in suppressing 5th harmonics so can reduce average value of voltage and current harmonics significantly within IEEE 519-1992.

Keywords: Power Quality, Total Harmonic Distortion, Multi PV Generator, Temperature, Irradiance

1. INTRODUCTION

Microgrid with distributed generations (DGs) sources in which electricity is supplied to local loads and may operate separately from conventional grid. DGs have many benefits such as being able to reduce transmission costs, lower investment costs, reduce distribution line losses and improve grid reliability. DGs using renewable energy to generate power are classified as disperse energy sources. Solar or PV generator are one of the most potential DGs technologies because they only require sunlight to generate electricity, where their resources are available in abundance, free, and relatively clean [1]. In order to support 35 thousand MW electricity program, starting in early 2016 Indonesia government will build a number of PV generator in the urban areas on the top of urban buildings called name roof top PV, as one solution to develop small scale electric power. The consideration is more on economic aspect because development of conventional PV generator requires relatively wide land, whereas price of land in urban areas is very expensive. The roof top PV will be deployed on several roofs of government buildings and airports in eastern Indonesia. It also will be integrated into Indonesia Electric Company (PLN) distribution network, so that if there is an excess of power, the PV power can be supplied and purchased by PLN [2].

The weakness of PV generator is in addition to supply power to grid, it also generates harmonics due to the presence of an inverter as a medium to convert DC voltage to AC so can reduce power quality in system. PV generator also has intermitten characteristic and generate power depend on environment condition e.g. temperature and irradiance level. Research of power quality problem on grid connected to PV system using LCL filter has been done by Kon Keng Weng et. al. The simulation results indicate that a number of electrical power quality problems such as over voltage, less voltage, power fluctuations, inrush currents, low power factor, and current harmonics will appear on microgrid. The disadvantage is that research is conducted only on conditions of certain solar irradiance and

temperature (1000 W/m² and 25°C) as environmental input parameters for PV systems [1]. Minas Patsalides, et.al has made investigation an effect of solar irradiance on grid connected PV generator to power quality e.g. voltage harmonics, current harmonics, active power, reactive power, and power factor. The study considers on two different scenarios of average and low irradiance. The weakness of study is not to consider temperature effect as variable environment input of PV generator [3]. Renu, et. al. has conducted a research of grid conneted to single phase PV generator inverter using a current proportional resonant, proportional resonant integral, and genetic algorithm controller using active filter to reduce current harmonic on inverter output. The shortcoming of research is only performed on a single phase system as well as fixed solar irradiance and temperature [4].

Massoud Farhoodnea, et. al. has examined analysis of dynamic power quality due to high penetration effect of grid connected to PV array on distribution system under different solar irradiance condition. The analysis was performed on a 16 bus system model and the result showed that high level penetration of grid connected PV would cause a number of power quality problems e.g. voltage swell, voltage flicker, power factor losses and current harmonics. The weakness of research is the analysis only held on voltage harmonics and does not consider enviromental temperature condition [5]. The research on power quality characteristics in a number of three phase PV inverters at roof top PV including harmonics distortion, voltage fluctuations, and reactive power and power factors have been performed by K.P. Kontogianis, et. al [6]. Almas Hossain Mollah, et.al. has investigates three phase grid connected to PV generator using MPPT with Perturb and Observe method and a voltage source inverter controller, as well as its effect on current harmonics injected into grid and grid voltage harmonics . The drawback of research are only carried out on single level of irradiance and temperature (1000 W/m² and 25°C) and does not consider harmonic improvement limitation (current and voltage) according to IEEE 519-1992 [7]. Amirullah, et. al. has examined the effect of PV power integration on power quality on three phase point common coupling (PCC) bus under different solar irradiance conditions using a double tuned filter. The results showed that at a fixed solar irradiance level, the more number of PV generator connected to three phase grid, average THD of voltage and current increased. While at the level of solar irradiance increased, average THD grid voltage and current also increased. Double tuned passive filters can reduce THD value of average voltage and current. The disadvantage is the research analysis is carried out at a fixed temperature level of 40°C, whereas the fact shows that ambient temperature is the main input variable for a PV generator other than solar irradiance whose value is always changing with time [8].

The objective of this paper is to improve the performance of power quality due to the influence of multi PV integration to low voltage distribution line of 380 kV (phase-phase) 50 Hz under variable solar temperature and irradiance level. The model consist of three PV generator groups with 100 kW active power each were used in this study. In addition to connecting on a three phase grid, the PV generator is also connected to three groups of three phase loads each having 20 kW active power. The power quality parameterr studied are the value of three phase voltage and current unbalance as well as voltage and current harmonics in eight scenarios PV generator connected on three phase grid. The band pass filter model (single tuned) is used to improve power quality using two conditions before and after filter installed. The simulation parameter results in PCC bus are further validated against to limit ANSI/IEEE 241-1990 (voltage and current unbalance) and IEEE 519-1992 (THD voltage and current), as the basis for determining power quality level. Simulation and research analysis use Matlab/Simulink environment. The rest of this paper is organized as follow. Section 2 shows research methodology which proposed model of single PV generator connected three phase grid, model of three PV generator connected three phase grid, simulation parameters, equivalent circuit and mathematical of PV model, harmonics and voltage/current unbalance, and single tuned filter model. Section 3 describes influence of variable solar irradiance and temperature level of three model PV generator to voltage and current unbalance as well as voltage and current THD without and with single tuned filter. In this section, example cases studied are presented and the results are verified with those of Matlab/Simulink. Finally, the paper in concluded in Section 4.

2. METHODOLOGY

2.1. Research Method

A system model of 100 kW single PV generator connected to a three phase grid is shown in Figure 1. The PV generator produces output voltage and becomes as input for DC/DC boost converter. The MPPT with Pertub and Observe algorithm further helps single phase PV generator result maximum power. The DC output voltage from PV generator is relatively low and then the voltage is increased by DC/DC boost converter to produce output voltage by adjusting duty cycle using switching equipment. The DC voltage is then converted by a three phase of DC/AC inverter to an AC voltage to three phase grid, using a six pulse width modulation (PWM) voltage source inverter controller based on proportional integral. Figure 2 shows proposed model of three groups of PV generator to 380

Volt (phase-phase) 50 Hz three phase low voltage on point common coupling (PCC) bus and 100 MVA 20 kV three phase grid through 100 kVA 20 kV/380 V three phase transformer.

The paper presents performance of power quality improvement on three phase grid of PCC bus due to influence of PV generator integration to 380 kV (phase-phase) 50 Hz low voltage distribution system at different temperature and irradiance conditions. The study used multi (three) models of PV generator each with an active power of 100 kW. The power quality parameters studied are voltage and current unbalance, as well as voltage and current harmonics in eight PV generator scenarios connected to three phase distribution on PCC bus at variable temperature and irradiance levels. The first scenario is before a single tuned filter installed at the irradiance level: (i) 400 W/m², (ii) 600 W/m², (iii) 800 W/m², and (iv) 1000 W/m². The second scenario is after installing a single tuned filter at the irradiance level: (i) 400 W/m², (ii) 600 W/m², (iii) 800 W/m², and (iv) 1000 W/m². The degree of temperature of each condition is 20^o C, 25^o C, 30^o C, 35^o C, and 40^oC. So the total scenario number are eight different irradiance levels (without and using a single tuned filter) where each of them are five temperature levels.

The simulation of circuit model is performed to determine voltage and current curve of three phase distribution line on PCC bus. To improve power quality performance, a model single passive band pass filter (single tuned) that serves suppress single 5th harmonics. A three phase circuit breaker (CB) is used to connect and disconnect a single tuned filter between PV generator with a three phase system. The next step is to determine voltage and current unbalance as well as voltage and current harmonics or total harmonics distortion (THD) of three phase grid on PCC bus in each scenario. The last step is to compare voltage and current unbalance as well as voltage and current THD of low distribution line on PCC bus referring to ANSI/IEEE 241-1990 and IEEE 519-1992 as the basis for determining power quality in eight irradiance and temperature level scenarios. Simulation and analysis of research results using Matlab/Simulink.

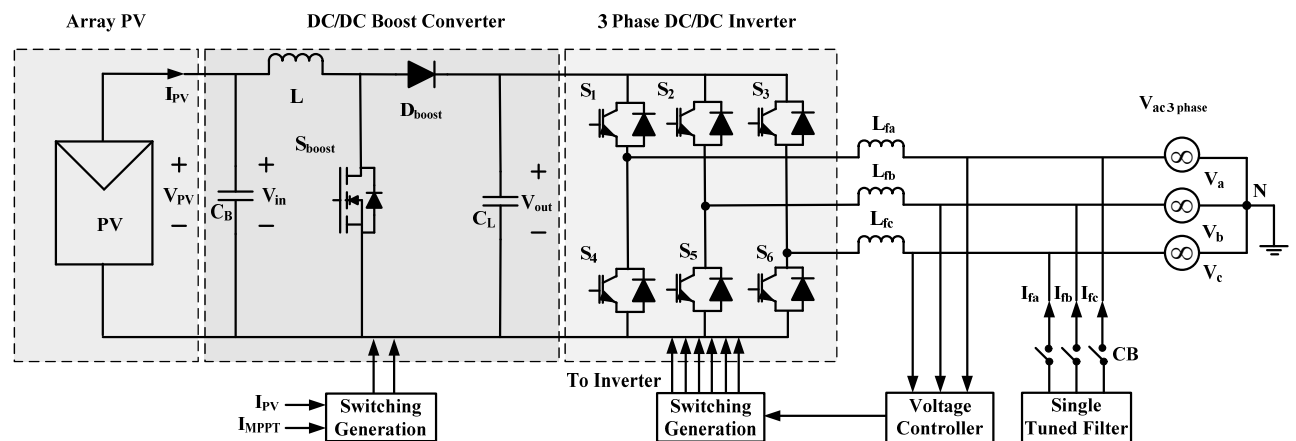

Figure 1. Model of single PV generator connected three phase grid

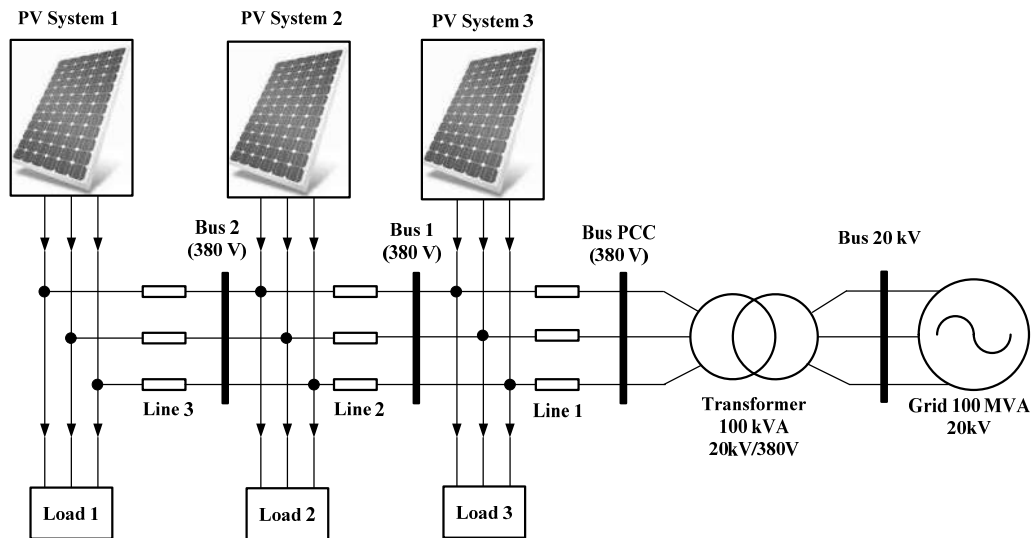

Figure 2. Proposed model of three PV generator connected to three phase grid

2.1. Simulation Parameters

Table 1 shows the devices, parameters, and simulation values of proposed model.

Table 1. Simulation Parameters

Devices	Parameters	Values
PV Generator 1, 2, and 3	Active Power Temperature Irradiance	100 kW 20 ⁰ , 25 ⁰ , 30 ⁰ , 35 ⁰ , and 40 ⁰ C 400, 600, 800, and 1000 W/m ²
Three Phase Grid	Short Circuit MVA Voltage (phase-phase) Frequency	100 MVA 380 volt 50 Hz
Power Transformer	Power Frequency Voltage	100 kVA 50 Hz 380 Volt/20 kV
Load 1, 2, and 3	Active Power Frequency Voltage	20 kW 380 Volt 50 Hz
Low Voltage Line 1,2, and 3	Resistance Inductance Capacitance	R = 0,1273 Ohm/km L = 93,37 mH/km C = 1,274 μF/km
Length of Low Voltage Line 1,2, and 3	Line 1 Line 2 Line 3	1 km 1 km 1 km
DC Link Capacitor	Capacitance	2000 μF
PWM Generator on Each PV Generator	Frequency Sampling time	4 kHz 5 x 10 ⁻⁶ detik
Single Tuned Filter	Reactive Power Voltage (phase-phase) Frequency System Frequency Tuning Quality Factor (Q)	50 MVAR 380 V 50 Hz f = 5 x 50 Hz 16

2.2. Photovoltaic Model

Figure 3 shows the equivalent circuit of a solar panel. A solar panel is composed of several PV cells that have series, parallel, or series-parallel external connections [9].

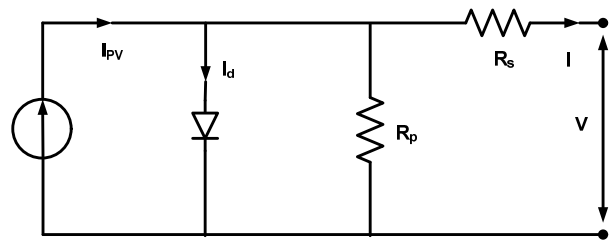

Figure 3. Equivalent circuit of solar panel

The V-I characteristic of a solar panel is showed in (1) [10] :

$$I = I_{PV} - I_o \left[\exp\left(\frac{V + R_s I}{aV_t}\right) - 1 \right] - \frac{V + R_s I}{R_p} \quad (1)$$

where I_{PV} is the photovoltaic current, I_o is saturated reverse current, 'a' is the ideal diode constant, $V_t = N_S K T q^{-1}$ is the thermal voltage, N_S is the number of series cells, q is the electron charge, K is the Boltzmann constant, T is the temperature of p-n junction, R_S and R_P are series and parallel equivalent resistance of the solar panels. I_{PV} has a linear relation with light intensity and also varies with temperature variations. I_o is dependent on temperature variations. The values of I_{PV} and I_o are calculated as following (2) and (3):

$$I_{PV} = (I_{PV,n} + K_I \Delta T) \frac{G}{G_n} \quad (2)$$

$$I_o = \frac{I_{SC,n} + K_I \Delta T}{\exp(V_{OC,n} + K_V \Delta T) / aV_t - 1} \quad (3)$$

In which $I_{PV,n}$, $I_{SC,n}$ and $V_{OC,n}$ are photovoltaic current, short circuit current and open circuit voltage in standard conditions ($T_n = 25$ C and $G_n = 1000$ Wm⁻²) respectively. K_I is the coefficient of short circuit current to temperature, $\Delta T = T - T_n$ is the temperature deviation from standard temperature, G is the light intensity and K_V is the ratio coefficient of open circuit voltage to temperature. Open circuit voltage, short circuit current and voltage-current corresponding to the maximum power are three important points of I-V characteristic of solar panel. These points are changed by variations of atmospheric conditions. By using (4) and (5) which are derived from PV model equations, short circuit current and open circuit voltage can be calculated in different atmospheric conditions.

$$I_{SC} = (I_{SC} + K_I \Delta T) \frac{G}{G_n} \quad (4)$$

$$V_{OC} = V_{OC} + K_V \Delta T \quad (5)$$

2.3. Harmonics and Voltage/Current Unbalance

Power quality means quality of voltage and current. Power quality is determined based on the voltage and current value or the tolerance limit of equipment used. In general, current and voltage wave form of pure sinusoidal waves. One problem that occurs is non sinusoidal or distorted current and voltage waves generated by harmonics in the power system [11]. Harmonic is distorted periodic steady state wave caused by the interaction between the shape of a sine wave at the fundamental frequency system with another wave component which is an integer multiples frequency of fundamental frequency. The most common harmonic index, which relates to the voltage waveform, is THD, which is defined as the root mean square (rms) of the harmonics expressed as a percentage of the fundamental component as showed in (12). For most applications, it is sufficient to consider the harmonic range from the 2nd to 25th, but most standards specify up to the 50th. Second harmonic index is current THD means the ratio of rms harmonic current value to rms fundamental current which expressed in (7) [11].

$$THD_V = \frac{\sqrt{\sum_{n=2}^N V_n^2}}{V_1} \times 100 \% \quad (6)$$

$$THD_I = \frac{\sqrt{\sum_{n=2}^N I_n^2}}{I_1} \times 100 \% \quad (7)$$

where V_n and I_n (the rms voltage and current at harmonic n), V_1 and I_1 (the fundamental rms voltage and current), N (the maximum harmonic order to be considered). The allowable maximum THD value for each country is different depending on the standard used. THD standards most often used in electric power system is IEEE 519-1992 standard. There are two criteria used in the analysis of harmonic distortion that voltage distortion limit and current distortion limit [13].

There are several standards that can be used to determine level of voltage unbalance in three phase systems, e.g. IEC, NEMA, and IEEE. In this study, value of unbalance voltage use Equation 8 is based ANSI/IEEE 241-1990 Standard [14] as follows:

$$V(\%) = \frac{|V_{a \text{ varage}} - V_{a,b,c \text{ min or max}}|}{V_{a \text{ varage}}} \times 100\% \quad (8)$$

By using Equation 8, value of unbalance voltage expressed in percent (%) and is defined as follows; V_{average} is the average value of maximum voltage on phase a, b, c, (volt), $V_{a,b,c \text{ min}}$ is minimum voltage on phase a, b, c, (volt), $V_{a,b,c \text{ max}}$ is maximum voltage on phase a, b, c (volt). By using the same equation, then percentage of unbalance current can be calculated by replacing voltage magnitude into current magnitude.

2.4. Single Tuned Filter

The shunt passive filters always considered as good solution to solve harmonics current problems. Shunt passive filters can be classified into three basic categories as follows (a) Band pass filters (of single or double tuned), (b) High pass filters (of first, second, third-order or C-type), and (c) Composite filters as shown in Figure 4. A single tuned filter consisting of inductor L_f , capacitor C_f and small damping resistor R_f are connected in parallel with non-linear loads to provide low-impedance paths for specific harmonic frequencies, thus resulting in absorbing the dominant harmonic currents flowing out of the load. Furthermore it also compensates reactive power at system operating frequency [15]. Single tuned passive filters are used to suppress single harmonics e.g. 5th, 7th, 9th, 11th, or 13th harmonics. Whereas double tuned passive filter is used to eliminate double harmonics such as the 5th and 57th harmonics or the 11th and 13th harmonics. In this paper a single tuned active filter model is used to reduce the 5th harmonics.

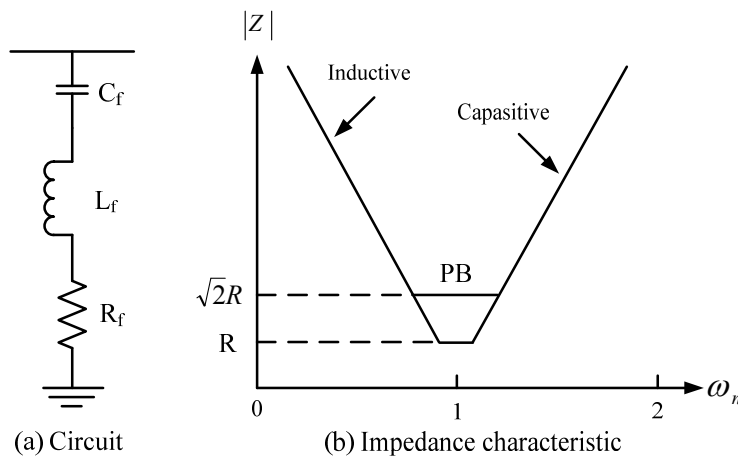

Figure 4. Single tuned filter circuit and impedance characteristic curve

Figure 4 shows a single tuned filter which is a series RLC circuit tuned to a single harmonics frequency provides a low harmonic impedance characteristic generally. As shown in Figure 4, the filter pass band (PB) is defined as being bounded by the frequencies at which the filter reactance is equal to its resistance; i.e., the impedance angle is 45° and the magnitude is $\sqrt{2}R$. Relationship between the quality factor and pass band can be expressed as follows [16]:

$$Q = \omega_n / PB \quad (9)$$

Where Q is defined as the ratio of the inductance (or capacitance) to resistance at the resonant frequency and ω_n is the tuned angular frequency (rad/s).

The impedance versus frequency of this filter is shown [15]:

$$Z_f(S) = \frac{1 + R_f C_f S + L_f C_f S^2}{C_f S} \quad (10)$$

Where $S = j2\pi f$

Generally the filter capacitor is sized for known reactive power compensation Q_c required to improve power factor, C_f can be expressed as:

$$C_f = \frac{1}{2\pi f_1 U^2} \left(1 - \frac{1}{n^2}\right) \quad (11)$$

Where U is the supply voltage, n is the harmonic order and f₁ is a fundamental frequency. At the harmonic frequency f_n = n f₁ the filter reactor provides a series resonance.

$$L_f 2\pi f_n = \frac{1}{C_f 2\pi f_n} \quad (12)$$

The inductive value of filter can be obtained from equation 6 as:

$$L_f = \frac{1}{(2\pi f_n)^2 C_f} \quad (13)$$

The value of the low-impedance R_f for each single tuned filter is affected by the quality factor of filter Q.

$$R_f = 2\pi f_1 n \frac{L_f}{Q} \quad (14)$$

The quality factor Q determines the sharpness of tuning. Usually, a value of Q ranges between 20 and 100. High Q-value filter give the best reduction in harmonic distortion. The interaction of the filter with the source reactance L_s, creates a parallel resonance condition addition to the series resonance frequency of the filter.

$$f_p = \frac{1}{2\pi(\sqrt{(L_f + L_s)C_f})} \quad (15)$$

3. RESULTS

Analysis of the results starts from determination of maximum and minimum grid voltages in each phase, to compute unbalanced voltage using Equation 8, as well as voltage THD of three phase grid on PCC bus without and with single tuned filter each. By using the same procedure and equation, then we get unbalance current and current THD of three phase grid. Table 2 shows unbalanced voltage and average voltage harmonics (THD_v) in three PV generator integration model to a three phase grid and four levels of irradiance with five different temperature levels. Table 3 shows the unbalanced current and average harmonic current (THD_i) on the PCC bus under the same condition.

Table 2. Voltage Unbalance and Voltage Average Harmonics

No.	Irradiance Level (W/m ²)	Temperature (°C)	Maximum Voltage (V)			Unbalance Voltage (%)	THD _v			Average THD _v (%)
			A	B	C		A	B	C	
Without Single Tuned Passive Filter										
1.	400	20	308	308	308	0	2.66	2.51	2.59	2.59
		25	308	308	308	0	2.62	2.56	2.56	2.58
		30	308	308	308	0	2.69	2.60	2.63	2.64
		35	310	310	310	0	2.67	2.53	2.59	2.60
		40	310	310	310	0	2.68	2.58	2.62	2.62
2.	600	20	308	308	308	0	3.59	3.60	3.63	3.61
		25	308	308	308	0	3.70	3.64	3.61	3.65
		30	308	308	308	0	3.61	3.55	3.49	3.55
		35	310	310	310	0	3.66	3.56	3.55	3.59
		40	310	310	310	0	3.66	3.60	3.54	3.60
3	800	20	310	310	310	0	4.16	4.19	4.06	4.14
		25	310	310	310	0	4.21	4.21	4.12	4.18
		30	310	310	310	0	4.12	4.14	3.99	4.11
		35	310	310	310	0	4.16	4.14	4.06	4.12
		40	310	310	310	0	4.11	4.14	4.03	4.10
4.	1000	20	310	310	310	0	4.12	4.08	4.01	4.07
		25	310	310	310	0	4.15	4.07	3.98	4.06
		30	310	310	310	0	4.04	3.99	3.93	3.98
		35	310	310	310	0	4.03	3.94	3.90	3.96
		40	310	310	310	0	4.03	3.90	3.90	3.94
With Single Tuned Passive Filter										
1.	400	20	308	308	308	0	0.22	0.23	0.22	0.22
		25	308	308	308	0	0.22	0.23	0.23	0.23
		30	308	308	308	0	0.23	0.23	0.22	0.23
		35	310	310	310	0	0.23	0.23	0.23	0.23

		40	310	310	310	0	0.23	0.23	0.23	0.23
2.	600	20	308	308	308	0	0.33	0.33	0.34	0.33
		25	308	308	308	0	0.34	0.34	0.34	0.34
		30	308	308	308	0	0.34	0.34	0.34	0.34
		35	310	310	310	0	0.34	0.33	0.34	0.34
		40	310	310	310	0	0.35	0.34	0.35	0.35
3	800	20	308	308	308	0	0.42	0.43	0.43	0.43
		25	308	308	308	0	0.43	0.43	0.43	0.43
		30	308	308	308	0	0.43	0.41	0.43	0.42
		35	310	310	310	0	0.42	0.42	0.42	0.42
		40	310	310	310	0	0.43	0.42	0.43	0.43
4.	1000	20	310	310	310	0	0.43	0.43	0.43	0.43
		25	310	310	310	0	0.41	0.42	0.43	0.42
		30	310	310	310	0	0.42	0.42	0.42	0.42
		35	310	310	310	0	0.41	0.42	0.42	0.42
		40	310	310	310	0	0.41	0.42	0.42	0.42

Table 3. Unbalance Current and Current Average Harmonics

No	Irradiance Level (W/m ²)	Temperature (°C)	Maximum Current (A)			Unbalance Current (%)	THD _i			Average THD _i (%)
			A	B	C		A	B	C	
Without Single Tuned Passive Filter										
1.	400	20	12.5	9.5	10	17.1875	2.01	1.27	1.69	1.657
		25	12.4	9.8	10	15.5278	2.02	1.26	1.68	1.654
		30	12.5	9.8	10	16.0991	2.01	1.27	1.68	1.653
		35	12.5	9.8	10	16.0991	2.02	1.27	1.70	1.663
		40	12.5	9.8	10	16.0991	2.02	1.27	1.70	1.663
2.	600	20	12.5	9.8	10	16.0991	2.28	1.47	1.93	1.893
		25	12.5	9.8	10	16.0991	2.23	1.47	1.83	1.843
		30	12.5	9.8	10	16.0991	2.01	1.27	1.68	1.653
		35	12.5	9.8	10	16.0991	2.02	1.27	1.70	1.663
		40	12.5	9.8	10	16.0991	2.02	1.27	1.70	1.663
3	800	20	12.5	9.8	10	16.0991	2.29	1.57	1.95	1.937
		25	12.5	9.8	10	16.0991	2.30	1.56	1.95	1.936
		30	12.5	9.8	10	16.0991	2.29	1.55	1.95	1.930
		35	12.5	9.8	10	16.0991	2.29	1.55	1.95	1.930
		40	12.5	9.8	10	16.0991	2.29	1.55	1.93	1.923
4.	1000	20	12.5	9.8	10	16.0991	2.36	1.63	1.88	1.957
		25	12.5	9.8	10	16.0991	2.35	1.64	1.87	1.953
		30	12.5	9.8	10	16.0991	2.34	1.63	1.87	1.947
		35	12.5	9.8	10	16.0991	2.32	1.62	1.86	1.933
		40	12.5	9.8	10	16.0991	2.32	1.61	1.83	1.920
With Single Tuned Passive Filter										
1.	400	20	10.45	10.45	10.45	0	0.09	0.09	0.09	0.09
		25	10.45	10.45	10.45	0	0.09	0.09	0.09	0.09
		30	10.45	10.45	10.45	0	0.09	0.09	0.09	0.09
		35	10.45	10.45	10.45	0	0.09	0.09	0.09	0.09
		40	10.45	10.45	10.45	0	0.09	0.09	0.09	0.09
2.	600	20	10.45	10.45	10.45	0	0.13	0.13	0.13	0.13
		25	10.45	10.45	10.45	0	0.13	0.13	0.13	0.13
		30	10.45	10.45	10.45	0	0.13	0.13	0.13	0.13
		35	10.45	10.45	10.45	0	0.13	0.13	0.13	0.13
		40	10.45	10.45	10.45	0	0.13	0.13	0.13	0.13
3	800	20	10.45	10.45	10.45	0	0.17	0.17	0.17	0.17
		25	10.45	10.45	10.45	0	0.17	0.17	0.16	0.17
		30	10.45	10.45	10.45	0	0.17	0.17	0.17	0.17
		35	10.45	10.45	10.45	0	0.17	0.17	0.16	0.17
		40	10.45	10.45	10.45	0	0.17	0.16	0.16	0.16
4.	1000	20	10.45	10.45	10.45	0	0.17	0.17	0.17	0.17

		25	10.45	10.45	10.45	0	0.17	0.17	0.17	0.17
		30	10.45	10.45	10.45	0	0.16	0.16	0.16	0.16
		35	10.45	10.45	10.45	0	0.16	0.16	0.16	0.16
		40	10.45	10.45	10.45	0	0.16	0.16	0.16	0.16

Figure 5 shows a grid voltage curve of PV generator model connected three phase grid on two levels of solar irradiance (600 W/m^2 and 1000 W/m^2) in PCC bus without and with single tuned filter.

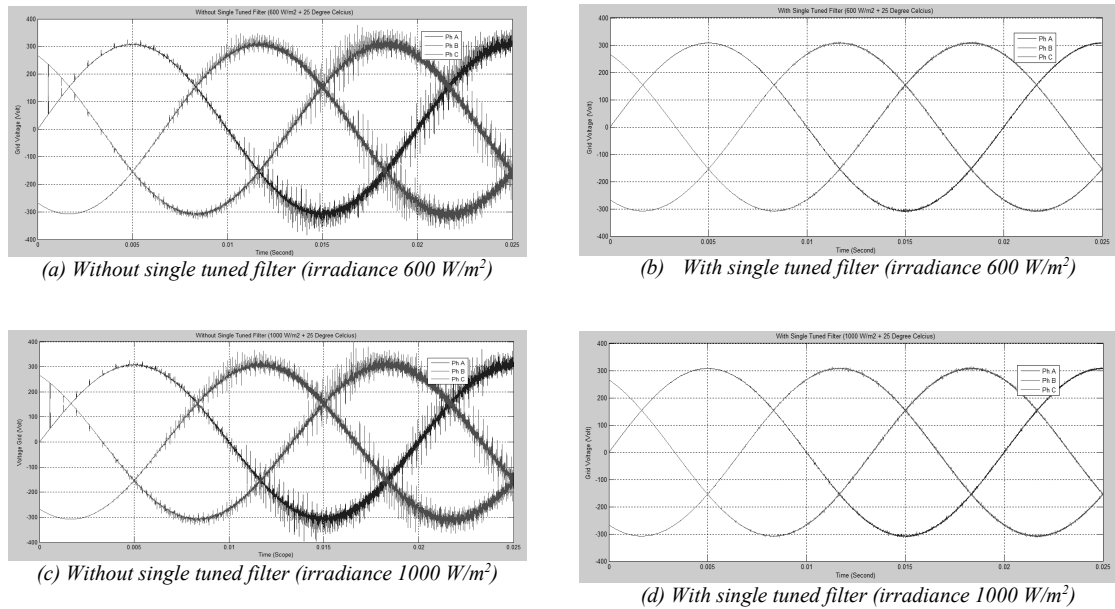

Figure 5. Grid Voltage Curve at Two Levels of Solar Irradiance with Temperature of 25° C

Figure 6 shows harmonics spectra of grid voltage of PV generator model connected three phase grid on two levels of solar irradiance (600 W/m^2 and 1000 W/m^2) in PCC bus without and with single tuned filter.

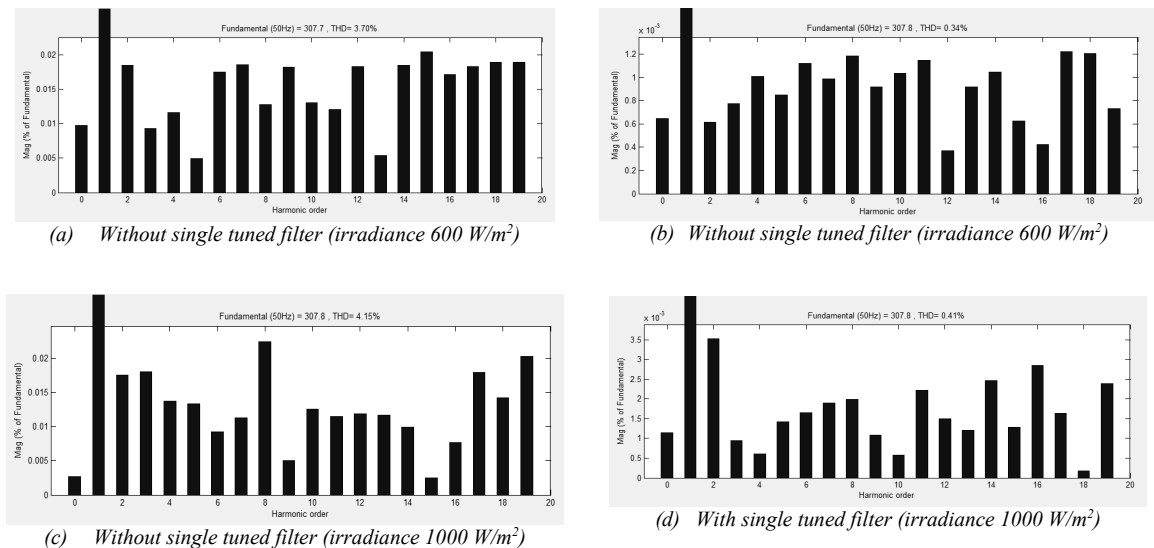

Figure 6. Grid Voltage Harmonics Spectra on Phase A at Two Levels of Solar Irradiance with Temperature of 25° C

Figure 7 shows the graph of voltage and current average harmonics values in three PV generator model connected three phase grids on PCC bus at four levels of irradiance (temperature 25⁰ C), without and with single tuned passive filter.

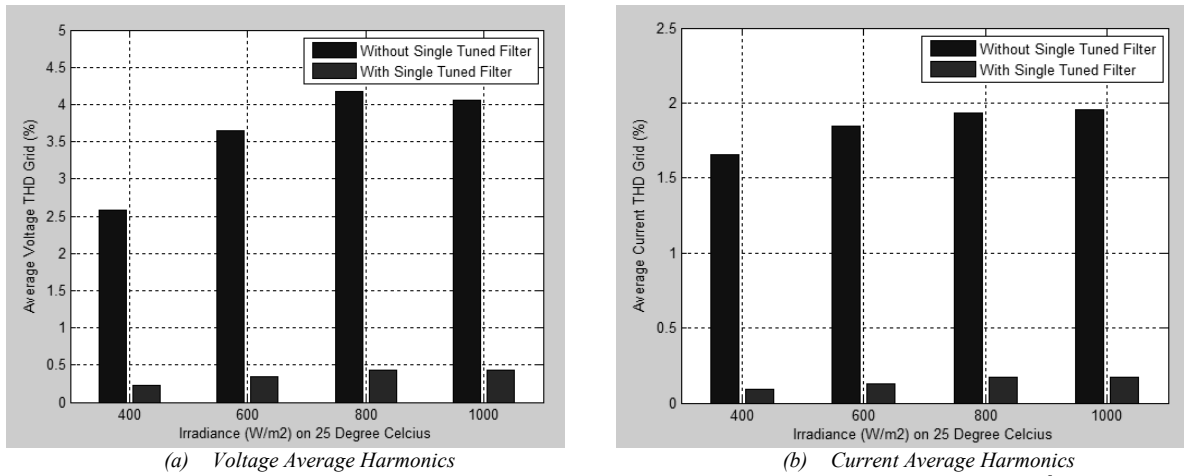

Figure 7. Average Harmonic of Voltage and Current at Four Irradiance Levels (Temperature 25⁰C)

Table 2 shows that maximum voltage values (phase A, B, and C), systems without single tuned filter at all irradiance levels (400 W/m² to 1000 W/m²) and temperatures (20 °C to 40°C) are still stable at 308 and 310 Volt, resulting in an unbalanced voltage as 0%. The maximum phase voltage value of system using single tuned filter at all irradiance levels and temperatures (20°C, 250C, and 300C) is equal to 308 volt and at temperatures (350C and 400C) the value increases to 310 Volt respectively, resulting in same unbalance voltage of 0%. Under conditions without using single tuned filter, the irradiance level is fixed and the temperature increases (20°C to 40°C), voltage average harmonics (THD_v) is relatively same. Otherwise in the conditions without filter and temperature remain, but in irradiance level increases, then voltage average harmonics increases. The lowest harmonic value is generated at irradiance level of 400 W/m² and temperature of 25⁰C is 2.58%, while the highest harmonic occurs at the irradiance level of 800 W/m² and temperature of 25⁰C is 4.18%. Under the same conditions using single tuned filter, fixed irradiance level, and temperature increases (20°C to 40°C), voltage average harmonic is relatively same. In unfiltered condition and fixed temperature, but irradiance level is increasing, then voltage average harmonic is also increasing. The difference is single tuned filter can suppress the 5th harmonics so as to lower voltage average harmonics significantly compared to system without using filters to average below 0.5%. In the system using single tuned filter, the lowest voltage average harmonics is generated at 400 W/m² irradiance level and temperature of 20°C as 0.22%, while the highest voltage average harmonics happens at irradiance level of 800 W/m² and temperature of 25⁰C is 0.43%.

Table 2 shows that maximum current values in phase A, B, and C, for systems without using single tuned filters at all irradiance levels (400 W/m² to 1000 W/m²) and temperature (20°C to 40°C) are 12.5, 9.8 and 10 A respectively, so unbalanced current is achieve 16.0991%. In the same condition the single tuned filter is able to balance maximum phase currents of 10.45 A each, resulting in an unbalanced current equal to 0%. Under conditions without using single tuned filter, fixed irradiance level, and temperature increases (20°C to 40°C), current average harmonics (THD_i) is relatively same. While at conditions without filter and temperature remain, but irradiance level is increasing, current average harmonics increases. The lowest current average harmonics is generated at 400 W/m² irradiance level and temperature of 25⁰C is 1.654%, while the highest current average harmonics occurs at irradiance level of 1000 W/m² and temperature of 20⁰C is 1.957%. Under conditions using single tuned filter, fixed irradiance level, and increasing temperature (20°C to 40°C), current average harmonics value is relatively same. Under unfiltered conditions and fixed temperature, but irradiance level is increasing, current average harmonics is also increasing. The use of single tuned filter can eliminate 5th harmonics so can reduce current average harmonics compared to without using filter to average below 0.2%. The lowest current average harmonic is generated at irradiance level of 400 W/m² and the temperature (200C to 40%) is 0.09%, while the highest current average harmonics at irradiance level of 800 W/m² and temperature of 25 °C as 0.17%.

Figure 7.a. shows that at increasing irradiance level (400 W/m² to 1000 W/m²) and fixed temperature (25⁰ C), voltage average harmonics is also increasing. The application of single tuned filter capable to suppress 5th harmonics so can reduce significantly reduce voltage average harmonics. Figure 7a also shows that at increasing irradiance level (400 W/m² to 1000 W/m²) and fixed temperature (25⁰ C), the current average harmonics is also increasing.

Single tuned active filter is also effective enough to eliminate 5th harmonics so as to slightly reduce current average harmonics.

4. CONCLUSION

Multi PV models with three phase generators connected three phase grid, without and with single tuned filters at all irradiance and temperature levels results phase maximum voltage (phase A, B, and C) in relatively stable of 308 and 310 Volt respectively, and generating unbalanced voltage of 0%. The maximum phase current value, for system without single tuned filter at all irradiance and temperature levels are different as 12.5, 9.8, and 10 A, respectively, resulting in unbalanced current of 16.0991%. Under the same condition, single tuned filters are capable to balance maximum phase currents (phase A, B, and C) of 10.45 A respectively, so able to reduce unbalanced current to 0%. The implementation of single tuned filter can reduce unbalanced current values according limit ANSI/IEEE 241-1990. At a constant temperature and irradiance levels are increasing, average harmonics of voltage and current is also increasing. The use of single tuned filter is the most effective in suppressing 5th harmonics so can reduce average value of voltage and current harmonics significantly within IEEE 519-1992.

REFERENCES

- [1]. Kow Ken Weng, Wong Yee Wan, Rajparthiban Kumar Rajkumar, Rajprasad Kumar Rajkumar, (2015), *Power Quality Analysis for PV Grid Connected System Using PSCAD/EMTDC*, International Journal of Renewable Energy Research, Vol.5, No.1, 2015, Turkey.
- [2]. <http://bisnis.news.viva.co.id/news/read/637325-cara-pemerintah-kembangkan-listrik-tenaga-surya-di-perkotaan>, tanggal akses 18/03/2017.
- [3]. Minas Patsalides, Demetres Evagorou, George Makrides, Zenon Achillides, George E. Georghiou, Andreas Stavrou, Venizelos Efthimiou, Bastian Zinsser, Wolfgang Schmitt and Jürgen H. Werner, *The Effect of Solar Irradiance on the Power Quality Behaviour of Grid Connected Photovoltaic Systems*, Department of Electrical and Computer Engineering, University of Cyprus, Electricity Authority of Cyprus, Institut für Physikalische Elektronik Pfaffenwaldring, Stuttgart, Germany.
- [4]. Renu.V and Surasmi N. L, (2014), *Optimal Control of Selective Harmonic Elimination in a Grid-Connected Single-Phase PV Inverter*, International Conference on Advances in Green Energy (ICAGE), Page 17-18, December 2014, Trivandrum, India.
- [5]. Masoud Farhoodnea, Azah Mohamed, Hussain Shareef, Hadi Zayandehroodi, (2013), *Power Quality Analysis of Grid-Connected Photovoltaic Systems in Distribution Networks*, University Kebangsaan Malaysia (UKM), PRZEGLĄD ELEKTROTECHNICZNY.
- [6]. K.P.Kontogiannis1, G.A.Vokas, S. Nanou, S. Papatthanassiou, (2013), *Power Quality Field Measurements on PV Inverters*, International Journal of Advanced Research in Electrical, Electronics and Instrumentation Engineering, Vol. 2, Issue 11, November 2013, Page 5301-5314.
- [7]. Almas Hossain Mollah, Prof. G K Panda, Prof. P K Saha, 2013, *Three Phase Grid Connected Photovoltaic System with Maximum Power Point Tracking*, International Journal of Advanced Research in Electrical, Electronics and Instrumentation Engineering, Vol. 4, Issue 5, May 2015 Page: 4637-4647.
- [8]. Amirullah, Ontoseno Penangsang, Adi Soeprijanto, (2016), *Power Quality Analysis of Integration Photovoltaic Generator to Three Phase Grid under Variable Solar Irradiance Level*, TELKOMNIKA, Vol. 14, No. 1, March 2016, Page. 29-38.
- [9]. Yahia Bouzelata, Erol Kurt, Rachid Chenni, Necmi Altin, (2015), *Design and Simulation of Unified Power Quality Conditioner Fed by Solar Energy*, International Journal of Hydrogen Energy 40, Hal. 15267-15277, Published by Elsevier Sciencedirect.
- [10]. Ali Reza Reisi, Muhammad H. Moradi, Hemen Showkati, (2013), *Combined Photovoltaic and Unified Power Quality Controller to Improve Power Quality*, Solar Energy 88 (2013), pp.154-162.
- [11]. Amirullah, Agus Kiswantono, (2016), *Power Quality Enhancement of Integration Photovoltaic Generator to Grid under Variable Solar Irradiance Level using MPPT-Fuzzy*, International Journal of Electrical and Computer Engineering (IJECE), Vol. 6, No. 6, Dec 2016.
- [12]. Arrilaga, Jos and Watson, Neville, *Power System Harmonics*, Chicester: John Willey and Sons, 2003.
- [13]. Thomas M. Bloming, P.E. and Daniel J. Carnovale, P.E., *Application of IEEE Standar 519-1992 Harmonic Limits*, Presented at The 2005 IEEE IAS Pulp and Paper Industry Conference in Appleton, WI.
- [14]. ANSI/IEEE 241, *IEEE Recommended Practice for Electric Power Systems in Commercial Buildings*, 1990.
- [15]. Amirullah, Ontoseno Penangsang, Adi Soeprijanto, (2014), *Effect of Installation of Photovoltaic (PV) Generation to Power Quality in Industrial and Residential Customers Distribution Network*, International

Seminar Intelligent Technology and Its Application (ISITIA) ITS Surabaya, ISBN: 978-1-4799-7710-9, Surabaya, May 20th -21st, 2015.

- [16]. Young-Sik Cho and Hanju Cha, (2017), *Single-tuned Passive Harmonic Filter Design Considering Variances of Tuning and Quality Factor*, Journal of International Council on Electrical Engineering”, 1:1, 7-13, 11 July 2017, Taylor and Francis Publisher.